

THIS DRAWING IS UNPUBLISHED. RELEASED FOR PUBLICATION 20  
 © COPYRIGHT 20 BY TYCO ELECTRONICS CORPORATION. ALL RIGHTS RESERVED.

LOC	DIST	REVISIONS			
P	LTR	DESCRIPTION	DATE	DWN	APVD
CE	00	F REC PER ECR-08-024912	19NOV2008	DDE	SB

- ⚠ MATERIAL:
- CONNECTOR HOUSING: POLYESTER PBT, COLOR: SEE TABLE\*
  - PLUG ASSEMBLY:
    - PLUG BODY: PAS, COLOR: BEIGE\*
    - INTERNAL BODY: BRASS, NICKEL PLATED
    - INTERNAL COMPONENTS: PEI, COLOR: NATURAL
    - FERRULE: CERAMIC
    - FERRULE BASE: ALUMINUM ALLOY
    - PLUNGER: ALUMINUM ALLOY
    - SPRING: STAINLESS STEEL
  - TERMINATION COVER: PEI, COLOR: BLACK\*
  - PROTECTIVE CAP: VINYL, COLOR: BLACK
  - CRIMP EYELET: COPPER, TIN PLATED
  - INNER EYELET: BRASS
  - POLYMER TUBING: TYGON, COLOR: CLEAR  
HYTREL, COLOR: WHITE
  - STRAIN RELIEF/BOOT: POLYOLEFIN ELASTOMER, COLOR: SEE TABLE\*
- \*UL94 V-0 RATED AT QUALIFYING THICKNESS.

2. THIS KIT WILL TERMINATE:
- 900um TIGHT BUFFERED FIBER
  - 250um COATED FIBER
  - 2.5-3.0mm JACKETED CABLE
  - 900um BREAK-OUT KIT
  - 900um EASY STRIP OR SEMI-TIGHT BUFFERED FIBER

3. TIGHT BUFFER TO BE 900±50um.

4. ANY JACKETED CABLE USED WITH SC CONNECTORS MUST ALLOW FOR THE AXIAL MOVEMENT OF THE BUFFERED FIBER IN THE CABLE JACKET WHICH OCCURS WHEN AN SC CONNECTOR IS MATED TO ANOTHER CONNECTOR OR DEVICE. CERTAIN CABLE CONSTRUCTIONS DO NOT ALLOW AXIAL MOVEMENT AND ARE NOT SUITABLE FOR USE WITH SC CONNECTORS. REFER TO INSPECTION SPECIFICATION 129-1496 FOR A METHOD OF DETERMINING WHETHER A GIVEN CABLE CONSTRUCTION ALLOWS AXIAL MOVEMENT (RESULT OF THE BUFFER PULL TEST SHOULD MEASURE LESS THAN 2 LBF).

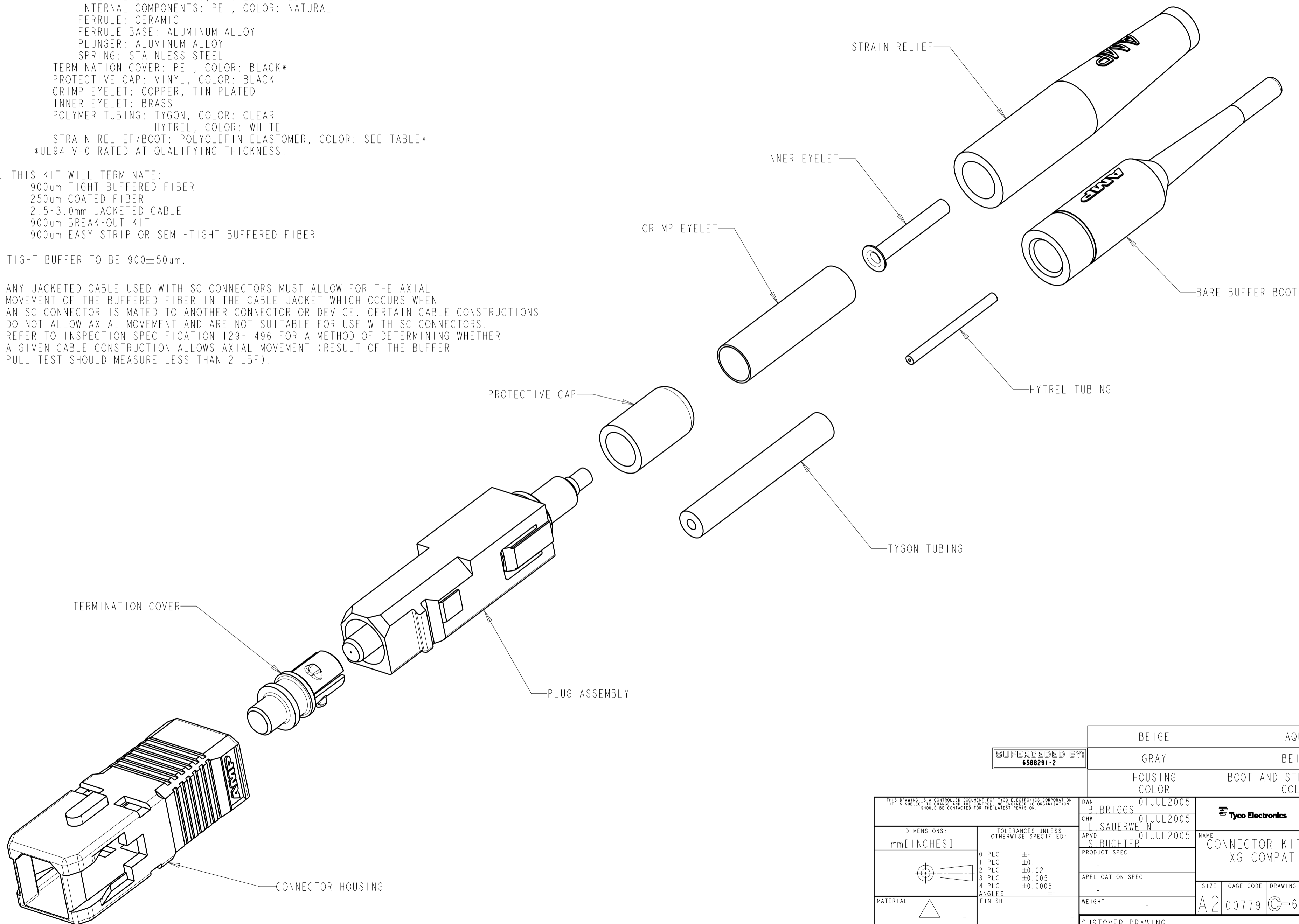

**SUPERCEDED BY:**  
6588291-2

BEIGE	AQUA	6588291-2
GRAY	BEIGE	6588291-1
HOUSING COLOR	BOOT AND STRAIN RELIEF COLOR	PART NUMBER

THIS DRAWING IS A CONTROLLED DOCUMENT FOR TYCO ELECTRONICS CORPORATION. IT IS SUBJECT TO CHANGE AND THE CONTROLLING ENGINEERING ORGANIZATION SHOULD BE CONTACTED FOR THE LATEST REVISION.		DWN B. BRIGGS 01 JUL 2005	Tyco Electronics Harrisburg, PA 17105-3608	
DIMENSIONS: mm [ INCHES ]		CHK L. SAUERWEIN 01 JUL 2005	NAME CONNECTOR KIT, LightCrimp Plus SC XG COMPATIBLE, 50/125um, MM	
TOLERANCES UNLESS OTHERWISE SPECIFIED: 0 PLC ±- 1 PLC ±0.1 2 PLC ±0.02 3 PLC ±0.005 4 PLC ±0.0005 ANGLES ±- FINISH		APVD S. BUCHTER 01 JUL 2005	PRODUCT SPEC -	RESTRICTED TO -
MATERIAL		APPLICATION SPEC -	WEIGHT -	SIZE A2
		CUSTOMER DRAWING	SCALE 4:1	SHEET 1 OF 1
				REV F